

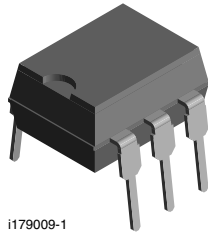

## Optocoupler, Phototransistor Output, no Base Connection

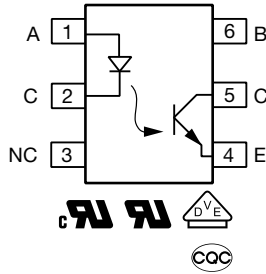

i179009-1



### FEATURES

- Isolation test voltage, 5300 V<sub>RMS</sub>
- No base terminal connection for improved common mode interface immunity
- Long term stability
- Industry standard dual in line package
- Material categorization: for definitions of compliance please see [www.vishay.com/doc?99912](http://www.vishay.com/doc?99912)



RoHS COMPLIANT

### LINKS TO ADDITIONAL RESOURCES



3D Models



Design Tools



Related Documents



SPICE Models



Footprints



Schematics

### AGENCY APPROVALS

- [UL](#)
- [cUL](#)
- [DIN EN 60747-5-5 \(VDE 0884\)](#), available with option 1
- [BSI EN 62368-1](#)
- [CQC GB4943.1-2011](#)
- [CQC GB8898-2011](#)

### DESCRIPTION

The MOC8101, MOC8102, MOC8103, MOC8104 family optocoupler consisting of a gallium arsenide infrared emitting diode optically coupled to a silicon planar phototransistor detector in a plastic plug-in DIP-6 package. The coupling device is suitable for signal transmission between two electrically separated circuits. The potential difference between the circuits to be coupled should not exceed the maximum permissible reference voltages.

The base terminal of the MOC8101, MOC8102, MOC8103, MOC8104 is not connected, resulting in a substantially improved common mode interference immunity.

### ORDERING INFORMATION

M	O	C	8	1	0	#	-	#	X	0	#	#	T
PART NUMBER							CTR BIN	PACKAGE OPTION				TAPE AND REEL	

AGENCY CERTIFIED / PACKAGE	CTR (%)			
	10 mA			
<b>UL, cUL, BSI, CQC</b>	<b>50 to 80</b>	<b>73 to 117</b>	<b>108 to 173</b>	<b>160 to 256</b>
DIP-6	MOC8101	MOC8102	MOC8103	MOC8104
DIP-6, 400 mil, option 6	-	MOC8102-X006	-	-
SMD-6, option 9	-	MOC8102-X009 <sup>(1)</sup>	-	-
<b>UL, cUL, BSI, CQC, VDE (Option 1)</b>	<b>50 to 80</b>	<b>73 to 117</b>	<b>108 to 173</b>	<b>160 to 256</b>
DIP-6	-	-	MOC8103-X001	-
DIP-6, 400 mil	-	MOC8102-X016	-	MOC8104-X016
SMD-6, option 7	MOC8101-X017T	MOC8102-X017T <sup>(1)</sup>	-	-
SMD-6, option 9	-	-	-	MOC8104-X019T

### Notes

- Additional options may be possible, please contact sales office
- <sup>(1)</sup> Also available in tubes; do not put T on end



ABSOLUTE MAXIMUM RATINGS ( $T_{amb} = 25\text{ }^{\circ}\text{C}$ , unless otherwise specified)				
PARAMETER	TEST CONDITION	SYMBOL	VALUE	UNIT
<b>INPUT</b>				
Reverse voltage		$V_R$	6.0	V
Forward continuous current		$I_F$	60	mA
Surge forward current	$t \leq 10\text{ }\mu\text{s}$	$I_{FSM}$	2.5	A
Power dissipation		$P_{diss}$	100	mW
Derate linearly from 25°C			1.33	mW/°C
<b>OUTPUT</b>				
Collector emitter breakdown voltage		$BV_{CEO}$	30	V
Emitter collector breakdown voltage		$BV_{ECO}$	7.0	V
Collector current		$I_C$	50	mA
Derate linearly from 25°C			2.0	mW/°C
Power dissipation		$P_{diss}$	150	mW
<b>COUPLER</b>				
Derate linearly from 25 °C			3.33	mW/°C
Total power dissipation		$P_{tot}$	250	mW
Storage temperature		$T_{stg}$	-55 to +150	°C
Operating temperature		$T_{amb}$	-55 to +100	°C
Junction temperature		$T_j$	100	°C
Soldering temperature <sup>(1)</sup>	max. 10 s, dip soldering: distance to seating plane $\geq 1.5\text{ mm}$	$T_{sld}$	260	°C

**Notes**

- Stresses in excess of the absolute maximum ratings can cause permanent damage to the device. Functional operation of the device is not implied at these or any other conditions in excess of those given in the operational sections of this document. Exposure to absolute maximum ratings for extended periods of the time can adversely affect reliability
- <sup>(1)</sup> Refer to reflow profile for soldering conditions for surface mounted devices (SMD). Refer to wave profile for soldering conditions for through hole devices (DIP)

ELECTRICAL CHARACTERISTICS ( $T_{amb} = 25\text{ }^{\circ}\text{C}$ , unless otherwise specified)							
PARAMETER	TEST CONDITION	PART	SYMBOL	MIN.	TYP.	MAX.	UNIT
<b>INPUT</b>							
Forward voltage	$I_F = 10\text{ mA}$		$V_F$	-	1.25	1.5	V
Breakdown voltage	$I_R = 10\text{ }\mu\text{A}$		$V_{BR}$	6.0	-	-	V
Reverse current	$V_R = 6.0\text{ V}$		$I_R$	-	0.01	10	$\mu\text{A}$
Capacitance	$V_R = 0\text{ V}$ , $f = 1.0\text{ MHz}$		$C_O$	-	25	-	pF
Thermal resistance			$R_{thja}$	-	750	-	K/W
<b>OUTPUT</b>							
Collector emitter capacitance	$V_{CE} = 5.0\text{ V}$ , $f = 1.0\text{ MHz}$		$C_{CE}$	-	5.2	-	pF
Collector emitter dark current	$V_{CE} = 10\text{ V}$ , $T_{amp} = 25\text{ }^{\circ}\text{C}$	MOC8101	$I_{CEO1}$	-	1.0	50	nA
	$V_{CE} = 10\text{ V}$ , $T_{amp} = 100\text{ }^{\circ}\text{C}$	MOC8102	$I_{CEO1}$	-	1.0	-	$\mu\text{A}$
Collector emitter breakdown voltage	$I_C = 1.0\text{ mA}$		$BV_{CEO}$	30	-	-	V
Emitter collector breakdown voltage	$I_E = 100\text{ }\mu\text{A}$		$BV_{ECO}$	7.0	-	-	V
Thermal resistance			$R_{thja}$	-	500	-	K/W
<b>COUPLER</b>							
Saturation voltage collector emitter	$I_F = 5.0\text{ mA}$		$V_{CEsat}$	-	0.25	0.4	V
Coupling capacitance			$C_C$	-	0.6	-	pF

**Note**

- Minimum and maximum values are testing requirements. Typical values are characteristics of the device and are the result of engineering evaluation. Typical values are for information only and are not part of the testing requirements



<b>CURRENT TRANSFER RATIO</b> ( $T_{amb} = 25\text{ }^{\circ}\text{C}$ , unless otherwise specified)							
PARAMETER	TEST CONDITION	PART	SYMBOL	MIN.	TYP.	MAX.	UNIT
Current transfer ratio	$V_{CE} = 10\text{ V}$ , $I_F = 10\text{ mA}$	MOC8101	CTR	50	-	80	%
		MOC8102	CTR	73	-	117	%
		MOC8103	CTR	108	-	173	%
		MOC8104	CTR	160	-	256	%

<b>SWITCHING CHARACTERISTICS</b> ( $T_{amb} = 25\text{ }^{\circ}\text{C}$ , unless otherwise specified)							
PARAMETER	TEST CONDITION	SYMBOL	MIN.	TYP.	MAX.	UNIT	
Turn-on time	$V_{CC} = 10\text{ V}$ , $I_C = 2.0\text{ mA}$ , $R_L = 100\text{ }\Omega$	$t_{on}$	-	3.0	-	$\mu\text{s}$	
Turn-off time	$V_{CC} = 10\text{ V}$ , $I_C = 2.0\text{ mA}$ , $R_L = 100\text{ }\Omega$	$t_{off}$	-	2.3	-	$\mu\text{s}$	
Rise time	$V_{CC} = 10\text{ V}$ , $I_C = 2.0\text{ mA}$ , $R_L = 100\text{ }\Omega$	$t_r$	-	2.0	-	$\mu\text{s}$	
Fall time	$V_{CC} = 10\text{ V}$ , $I_C = 2.0\text{ mA}$ , $R_L = 100\text{ }\Omega$	$t_f$	-	2.0	-	$\mu\text{s}$	
Cut off frequency		$f_{co}$	-	250	-	kHz	

<b>SAFETY AND INSULATION RATINGS</b>				
PARAMETER	TEST CONDITION	SYMBOL	VALUE	UNIT
Climatic classification	According to IEC 68 part 1		55 / 100 / 21	
Comparative tracking index		CTI	175	
Maximum rated withstanding isolation voltage	$t = 1\text{ min}$	$V_{ISO}$	4420	$V_{RMS}$
Maximum transient isolation voltage		$V_{IOTM}$	10 000	V
Maximum repetitive peak isolation voltage		$V_{IORM}$	890	V
Isolation resistance	$V_{IO} = 500\text{ V}$ , $T_{amb} = 25\text{ }^{\circ}\text{C}$	$R_{IO}$	$\geq 10^{12}$	$\Omega$
	$V_{IO} = 500\text{ V}$ , $T_{amb} = 100\text{ }^{\circ}\text{C}$	$R_{IO}$	$\geq 10^{11}$	$\Omega$
Output safety power		$P_{SO}$	400	mW
Input safety current		$I_{SI}$	275	mA
Input safety temperature		$T_{SI}$	175	$^{\circ}\text{C}$
Creepage distance	Standard DIP-6		$\geq 7$	mm
Clearance distance	Standard DIP-6		$\geq 7$	mm
Creepage distance	400 mil DIP-6		$\geq 8$	mm
Clearance distance	400 mil DIP-6		$\geq 8$	mm
Insulation thickness		DTI	$\geq 0.4$	mm

**Note**

- As per IEC 60747-5-5, § 7.4.3.8.2, this optocoupler is suitable for "safe electrical insulation" only within the safety ratings. Compliance with the safety ratings shall be ensured by means of protective circuits



## TYPICAL CHARACTERISTICS (T<sub>amb</sub> = 25 °C, unless otherwise specified)

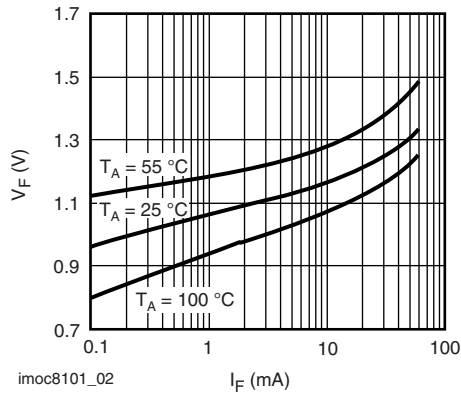

Fig. 1 - Forward Voltage vs. Forward Current

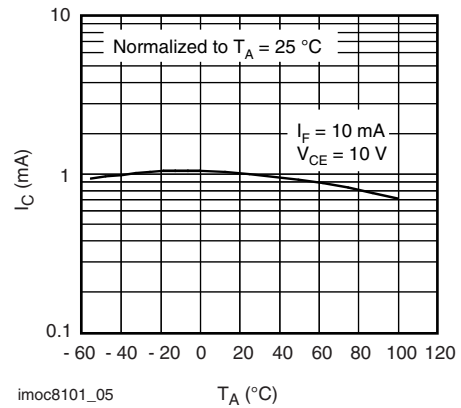

Fig. 4 - Collector Current vs. Ambient Temperature

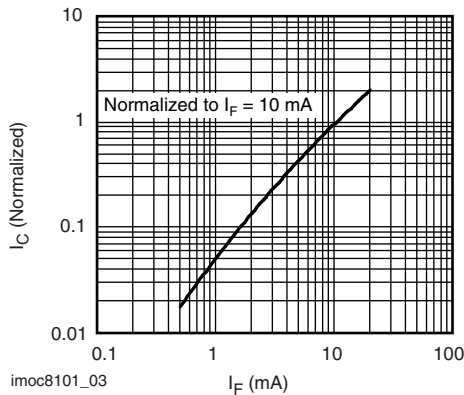

Fig. 2 - Collector Current vs. LED Forward Current

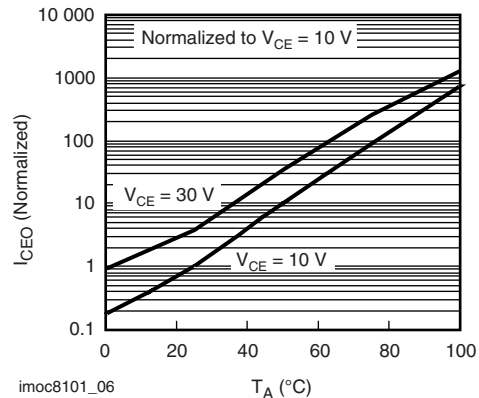

Fig. 5 - Collector Emitter Dark Current vs. Ambient Temperature

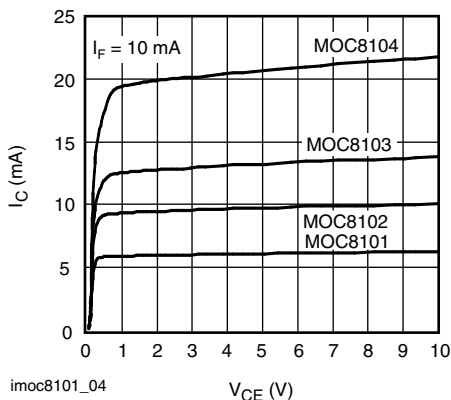

Fig. 3 - Collector Current vs. Collector Emitter Voltage

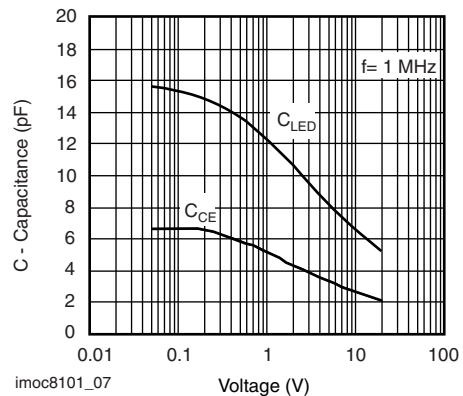

Fig. 6 - Capacitance vs. Voltage

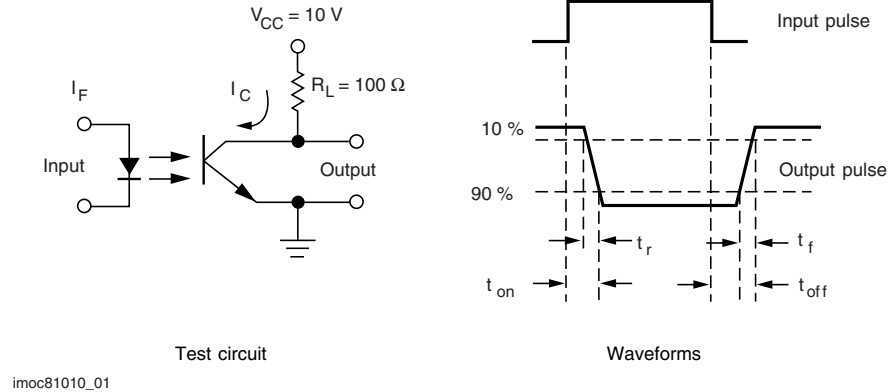
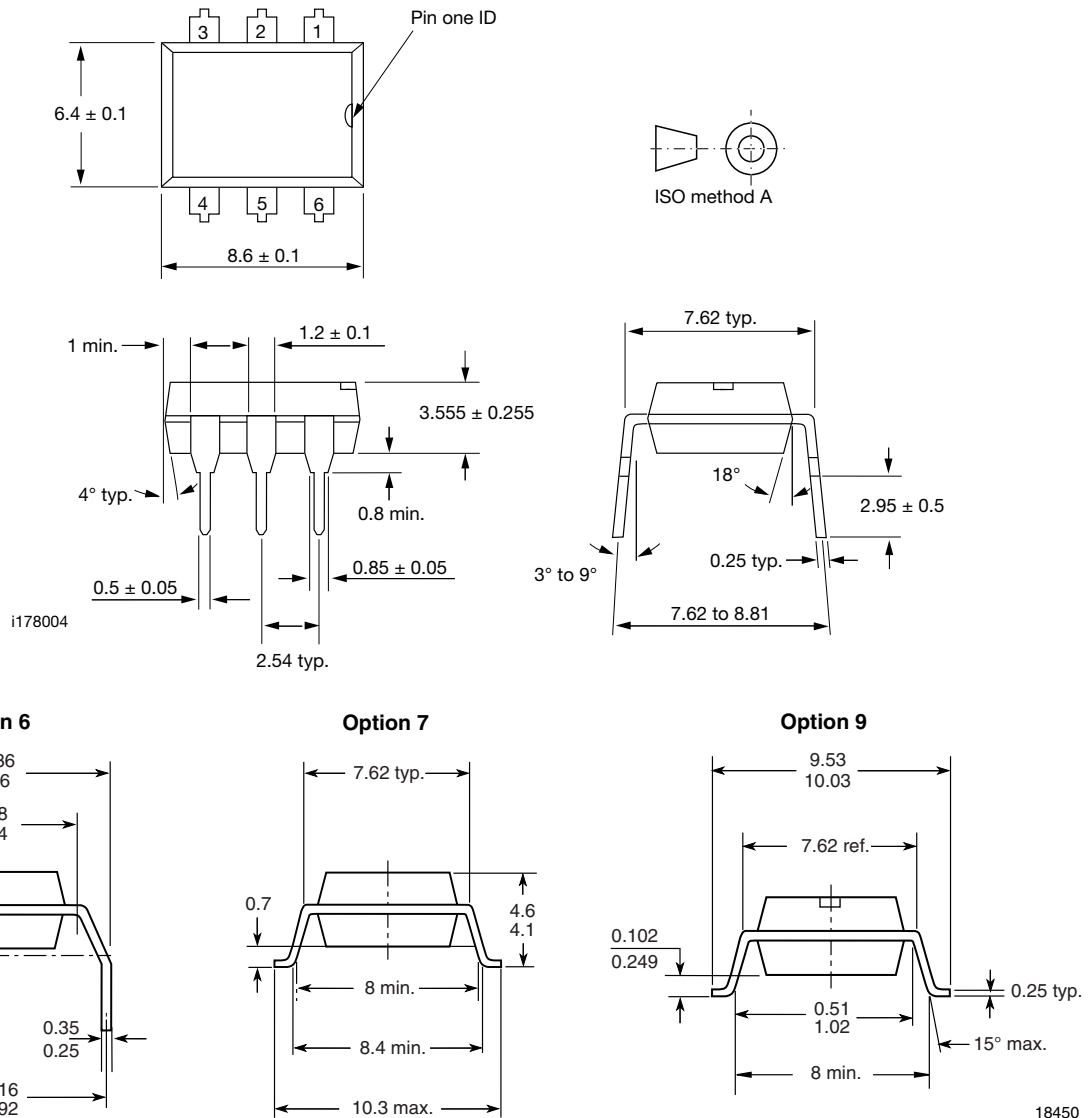

Fig. 7 - Switching Time Test Circuit and Waveforms

## PACKAGE DIMENSIONS in millimeters





## PACKAGE MARKING (example)

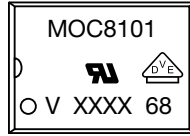

Fig. 8 - Example of MOC8101-X017T

### Notes

- XXXX = LMC (lot marking code)
- VDE logo is only marked on option 1 parts
- Tape and reel suffix (T) is not part of the package marking



## Disclaimer

ALL PRODUCT, PRODUCT SPECIFICATIONS AND DATA ARE SUBJECT TO CHANGE WITHOUT NOTICE TO IMPROVE RELIABILITY, FUNCTION OR DESIGN OR OTHERWISE.

Vishay Intertechnology, Inc., its affiliates, agents, and employees, and all persons acting on its or their behalf (collectively, "Vishay"), disclaim any and all liability for any errors, inaccuracies or incompleteness contained in any datasheet or in any other disclosure relating to any product.

Vishay makes no warranty, representation or guarantee regarding the suitability of the products for any particular purpose or the continuing production of any product. To the maximum extent permitted by applicable law, Vishay disclaims (i) any and all liability arising out of the application or use of any product, (ii) any and all liability, including without limitation special, consequential or incidental damages, and (iii) any and all implied warranties, including warranties of fitness for particular purpose, non-infringement and merchantability.

Statements regarding the suitability of products for certain types of applications are based on Vishay's knowledge of typical requirements that are often placed on Vishay products in generic applications. Such statements are not binding statements about the suitability of products for a particular application. It is the customer's responsibility to validate that a particular product with the properties described in the product specification is suitable for use in a particular application. Parameters provided in datasheets and / or specifications may vary in different applications and performance may vary over time. All operating parameters, including typical parameters, must be validated for each customer application by the customer's technical experts. Product specifications do not expand or otherwise modify Vishay's terms and conditions of purchase, including but not limited to the warranty expressed therein.

Hyperlinks included in this datasheet may direct users to third-party websites. These links are provided as a convenience and for informational purposes only. Inclusion of these hyperlinks does not constitute an endorsement or an approval by Vishay of any of the products, services or opinions of the corporation, organization or individual associated with the third-party website. Vishay disclaims any and all liability and bears no responsibility for the accuracy, legality or content of the third-party website or for that of subsequent links.

Except as expressly indicated in writing, Vishay products are not designed for use in medical, life-saving, or life-sustaining applications or for any other application in which the failure of the Vishay product could result in personal injury or death. Customers using or selling Vishay products not expressly indicated for use in such applications do so at their own risk. Please contact authorized Vishay personnel to obtain written terms and conditions regarding products designed for such applications.

No license, express or implied, by estoppel or otherwise, to any intellectual property rights is granted by this document or by any conduct of Vishay. Product names and markings noted herein may be trademarks of their respective owners.