

## NTC Thermistors, Miniature Immersion Sensor



### LINKS TO ADDITIONAL RESOURCES



| QUICK REFERENCE DATA  |             |          |
|---|-------------|----------|
| PARAMETER   | VALUE       | UNIT     |
| Resistance value at 25 °C   | 10K         | Ω        |
| Tolerance on $R_{25}$ -value  | ± 3         | %        |
| $B_{25/85}$ -value  | 3984        | K        |
| Tolerance on $B_{25/85}$ -value   | ± 0.5       | %        |
| Operating temperature range at zero dissipation                           | -25 to +105 | °C       |
| Response time $t_{63.2}$ % of $\Delta T$ (air 25 °C to water 85 °C)       | 1.5         | s        |
| Dissipation factor $\delta$   |             |          |
| Mounted in still air  | 2.8         | mW/K     |
| In still water  | 5.6         |          |
| Maximum power dissipation at 55 °C  | 100         | mW       |
| Min. dielectric withstanding voltage between terminals and capsule (10 s) | 500         | $V_{AC}$ |
| Insulation resistance at 500 $V_{DC}$                                     | > 100M      | Ω        |
| Thermal gradient  | < 0.02      | K/K      |
| Weight  | 2.1         | g        |

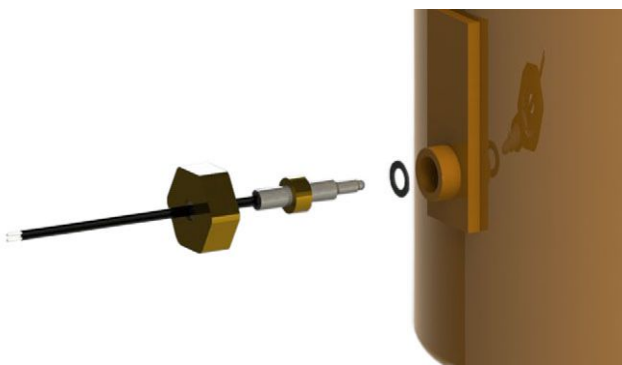

Fig. 1 - Mounting example with sealing ring and screw

### FEATURES

- Fast time response for fluid immersion applications
- Reduced thermal gradient, due to the use of small tip dimensions and thin insulated wire
- Sensor for permanent contact with water or other liquids
- Material categorization: for definitions of compliance please see [www.vishay.com/doc?99912](http://www.vishay.com/doc?99912)



**RoHS**  
COMPLIANT

### APPLICATIONS

Immersion sensor used for temperature measurement, sensing and control in:

- Water boilers
- Heating systems
- Chiller systems
- Water and used water systems
- Water and oil tanks
- Consumer appliances, coffee machines
- Industrial appliances
- Solar heating systems

### DESCRIPTION

Miniature insulated chip NTC thermistor mounted in a SS304 housing with or without brass collar for sealed mounting and twin PVC insulated AWG#30 lead wire connection.

### MOUNTING

- The sensor can be mounted by means of a sealing O-ring and screw
- The end wire can be soldered, or crimped to a connector
- Optional connector for Wire-to-Wire or Wire-to-Board connections
- The contact area with the liquid is preferably min 10 mm down from the tip and max to the brass collar location (see Fig. 1 for mounting example)
- Not intended for corrosive or high acidic liquids
- The epoxy lead-wire side can not be in permanent contact with liquids, or water

### PACKAGING

Available in plastic bags of 250 pieces.

### DESIGN-IN SUPPORT

- Other resistance curves and tolerances are available on request
- Consult Vishay for other lead length or connector options
- For complete RT curve computation, visit: [www.vishay.com/thermistors/ntc-rt-calculator/](http://www.vishay.com/thermistors/ntc-rt-calculator/)
- Available in high grade stainless steel SS316

| ELECTRICAL DATA AND ORDERING INFORMATION |                       |                    |                            |                                   |                                  |
|--|-----------------------|--------------------|----------------------------|-----------------------------------|----------------------------------|
| $R_{25}$<br>(Ω)                          | $R_{25}$ -TOL.<br>(%) | $B_{25/85}$<br>(K) | $B_{25/85}$ -TOL.<br>(± %) | DESCRIPTION                       | SAP MATERIAL AND ORDERING NUMBER |
| 10 000                                   | ± 3                   | 3984               | 0.5                        | NTC Immersion 10K 3 % 3984K 0.5 % | NTCAIMME3C90373                  |
| 10 000                                   | ± 3                   | 3984               | 0.5                        | NTC 10K 3 % 3984K 0.5 % no ring   | NTCAIMME3C90686                  |

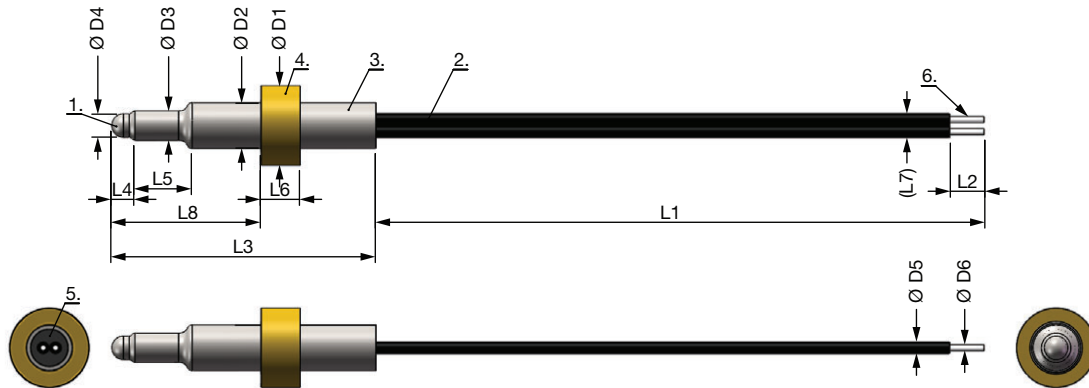
**DIMENSIONS** in millimeters

| L1       | L2    | L3       | L4      | L5      | L6        | L7   | L8       | Ø D1      | Ø D2      | Ø D3      | Ø D4    | Ø D5 | Ø D6 |
|----------|-------|----------|---------|---------|-----------|------|----------|-----------|-----------|-----------|---------|------|------|
| 200 ± 20 | 4 ± 1 | 23 ± 0.5 | 2 ± 0.5 | 5 ± 0.5 | 3.4 ± 0.2 | 2.05 | 13 ± 0.5 | 6.8 ± 0.1 | 3.9 ± 0.1 | 2.5 ± 0.2 | 2 ± 0.2 | 1    | 0.3  |

**Notes**

1. Vishay Thermistor chip NTC, epoxy insulated
2. PVC cable, single insulated 105 °C, 300 V rated, AWG#30 multi-stranded twin
3. Stainless steel (SS304) housing
4. Brass collar (not present on the NTCAIMME3C90686 type)
5. Epoxy potting resin
6. Pre-tinned end wire stripped

 For complete Curve Computation, visit: [www.vishay.com/thermistors/ntc-rt-calculator/](http://www.vishay.com/thermistors/ntc-rt-calculator/)

| RESISTANCE TEMPERATURE CHARACTERISTICS |                  |                   |                     |                   |                   |                   |                   |
|--|------------------|-------------------|---------------------|-------------------|-------------------|-------------------|-------------------|
| TEMP.<br>(°C)                          | $R_{(T)}/R_{25}$ | RESISTANCE<br>(Ω) | $\Delta R/R$<br>(%) | $\alpha$<br>(%/K) | $\Delta T$<br>(K) | $R_{MIN.}$<br>(Ω) | $R_{MAX.}$<br>(Ω) |
| -25                                    | 12.990           | 129 900           | 4.39                | -5.99             | 0.73              | 124 202           | 135 598           |
| -20                                    | 9.676            | 96 761            | 4.22                | -5.79             | 0.73              | 92 675            | 100 848           |
| -15                                    | 7.276            | 72 765            | 4.07                | -5.61             | 0.73              | 69 806            | 75 723            |
| -10                                    | 5.522            | 55 218            | 3.92                | -5.43             | 0.72              | 53 056            | 57 380            |
| -5                                     | 4.227            | 42 268            | 3.77                | -5.26             | 0.72              | 40 674            | 43 861            |
| 0                                      | 3.262            | 32 624            | 3.63                | -5.10             | 0.71              | 31 440            | 33 808            |
| 5                                      | 2.538            | 25 381            | 3.49                | -4.94             | 0.71              | 24 494            | 26 268            |
| 10                                     | 1.990            | 19 897            | 3.36                | -4.80             | 0.70              | 19 227            | 20 566            |
| 15                                     | 1.571            | 15 711            | 3.24                | -4.65             | 0.70              | 15 202            | 16 220            |
| 20                                     | 1.249            | 12 493            | 3.12                | -4.52             | 0.69              | 12 103            | 12 882            |
| 25                                     | 1.000            | 10 000            | 3.00                | -4.39             | 0.68              | 9700.0            | 10 300            |
| 30                                     | 0.8056           | 8056.0            | 3.11                | -4.26             | 0.73              | 7805.1            | 8306.8            |
| 35                                     | 0.6530           | 6529.7            | 3.22                | -4.14             | 0.78              | 6319.3            | 6740.2            |
| 40                                     | 0.5324           | 5323.9            | 3.33                | -4.03             | 0.83              | 5146.6            | 5501.1            |
| 45                                     | 0.4365           | 4365.3            | 3.43                | -3.92             | 0.88              | 4215.4            | 4515.1            |
| 50                                     | 0.3599           | 3598.7            | 3.53                | -3.81             | 0.93              | 3471.6            | 3725.8            |
| 55                                     | 0.2982           | 2982.3            | 3.63                | -3.71             | 0.98              | 2874.0            | 3090.5            |
| 60                                     | 0.2484           | 2483.8            | 3.72                | -3.61             | 1.03              | 2391.3            | 2576.3            |
| 65                                     | 0.2079           | 2078.7            | 3.81                | -3.51             | 1.09              | 1999.4            | 2157.9            |
| 70                                     | 0.1748           | 1747.7            | 3.90                | -3.42             | 1.14              | 1679.5            | 1815.9            |
| 75                                     | 0.1476           | 1475.9            | 3.99                | -3.34             | 1.20              | 1417.1            | 1534.8            |
| 80                                     | 0.1252           | 1251.8            | 4.07                | -3.25             | 1.25              | 1200.8            | 1302.8            |
| 85                                     | 0.1066           | 1066.1            | 4.15                | -3.17             | 1.31              | 1021.8            | 1110.4            |
| 90                                     | 0.09116          | 911.59            | 4.23                | -3.09             | 1.37              | 873.01            | 950.16            |
| 95                                     | 0.07825          | 782.46            | 4.31                | -3.02             | 1.43              | 748.75            | 816.17            |
| 100                                    | 0.06741          | 674.11            | 4.38                | -2.94             | 1.49              | 644.56            | 703.66            |
| 105                                    | 0.05828          | 582.84            | 4.46                | -2.87             | 1.55              | 556.87            | 608.82            |



## Disclaimer

ALL PRODUCT, PRODUCT SPECIFICATIONS AND DATA ARE SUBJECT TO CHANGE WITHOUT NOTICE TO IMPROVE RELIABILITY, FUNCTION OR DESIGN OR OTHERWISE.

Vishay Intertechnology, Inc., its affiliates, agents, and employees, and all persons acting on its or their behalf (collectively, "Vishay"), disclaim any and all liability for any errors, inaccuracies or incompleteness contained in any datasheet or in any other disclosure relating to any product.

Vishay makes no warranty, representation or guarantee regarding the suitability of the products for any particular purpose or the continuing production of any product. To the maximum extent permitted by applicable law, Vishay disclaims (i) any and all liability arising out of the application or use of any product, (ii) any and all liability, including without limitation special, consequential or incidental damages, and (iii) any and all implied warranties, including warranties of fitness for particular purpose, non-infringement and merchantability.

Statements regarding the suitability of products for certain types of applications are based on Vishay's knowledge of typical requirements that are often placed on Vishay products in generic applications. Such statements are not binding statements about the suitability of products for a particular application. It is the customer's responsibility to validate that a particular product with the properties described in the product specification is suitable for use in a particular application. Parameters provided in datasheets and / or specifications may vary in different applications and performance may vary over time. All operating parameters, including typical parameters, must be validated for each customer application by the customer's technical experts. Product specifications do not expand or otherwise modify Vishay's terms and conditions of purchase, including but not limited to the warranty expressed therein.

Hyperlinks included in this datasheet may direct users to third-party websites. These links are provided as a convenience and for informational purposes only. Inclusion of these hyperlinks does not constitute an endorsement or an approval by Vishay of any of the products, services or opinions of the corporation, organization or individual associated with the third-party website. Vishay disclaims any and all liability and bears no responsibility for the accuracy, legality or content of the third-party website or for that of subsequent links.

Vishay products are not designed for use in life-saving or life-sustaining applications or any application in which the failure of the Vishay product could result in personal injury or death unless specifically qualified in writing by Vishay. Customers using or selling Vishay products not expressly indicated for use in such applications do so at their own risk. Please contact authorized Vishay personnel to obtain written terms and conditions regarding products designed for such applications.

No license, express or implied, by estoppel or otherwise, to any intellectual property rights is granted by this document or by any conduct of Vishay. Product names and markings noted herein may be trademarks of their respective owners.